

## 200M InGaAs APD Preamplifier Module

### CR200AH-1550-100M-00

The CR200AH-1550-100M-00 includes a 200um InGaAs Avalanche Photodiode with a hybrid preamplifier for the use in high speed, ultra-low light detection, in laser range finding, LIDAR and free space communication.

#### ■ Features

- Built in 200um InGaAs+TIA
- High sensitivity:  $\geq 400\text{kV/W}$
- High bandwidth: 100Mhz
- Wavelength range:1100~1700nm
- Low noise and high reliability
- TO8 package with flat window
- Enhanced overload protection

#### ■ Applications

- LIDAR
- Laser range finding
- Free space optical communication (FSO)

#### ■ Absolute Maximum Ratings

Parameter	Unit	Symbol	Rating
Reverse breakdown voltage	V	V R	VBR
Operating temperature	°C	T C	-40~+85
Storage temperature	°C	T STG	-55~+100
Maximum optical input power	mW	P in	100
Module mains voltage	V	Vcc/V EE	$\pm 5$
Power dissipation	mW	Pw	250
Soldering temperature(time)	°C	-	300 (10s)

#### ■ Optical/Electrical Characteristics (T=25°C, unless otherwise stated)

Parameter	Symbol	Value			Unit	Test conditions
		Min	Typ	Max		
Response Spectrum	$\lambda$	1100~1700			nm	
Active Diameter	D		200		um	
Reverse breakdown voltage	VBR	30		70	V	
Operating voltage	VR	VR-3			V	M=10

Responsivity	R <sub>v</sub>	400			kV/W	M=10, 1.55um @τ=5ns
Dynamic range	DY	25			dB	M=10, 1.55um @τ=5ns
-3dB bandwidth	BW		100		Mhz	M=10, 1.55um @τ=100ns
Rise/Fall time	t <sub>r</sub>		3.5		ns	M=10, 1.55um @τ=100ns
Noise Equivalent Power	NEP		120		fW/√Hz	M=10 , f=100kHz, Δ =1hz
Output impedance	R <sub>O</sub>		50		Ω	
Output Voltage Swing	V <sub>O</sub>	0.7			V	
Positive Supply Current	I <sub>CC</sub>			30	mA	
Negative Supply Current	I <sub>EE</sub>			10	mA	50Ω Load
Temperature coefficient of Vop for constant gain	γ		0.12		V/ o C	-45 ~ 85°C
Concentricity	Δ D			20	um	

**■ Schematic Block Diagram**

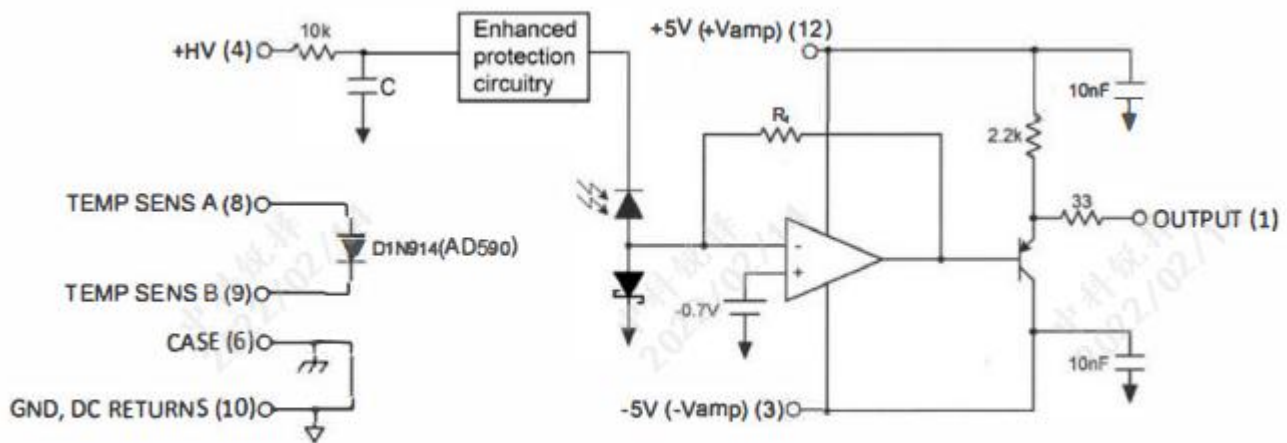

**■ Block Diagram and Pin description**

Dimensions are in millimeters. All dimensions are ±0.1mm unless otherwise specified.

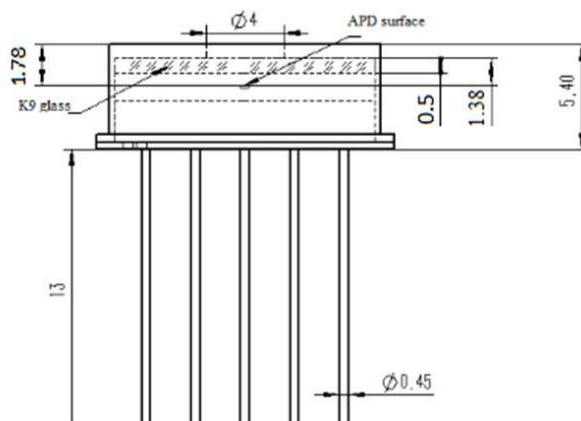

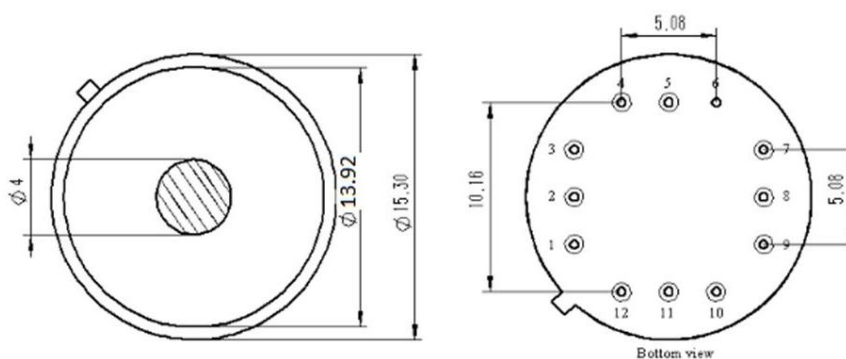

Pin description

PIN#	DESC	PIN#	DESC
1	OUTPUT	7	NC
2	NC	8	TEMP SENS A
3	-5V	9	TEMP SENS B
4	HV,APD BIAS	10	GND
5	NC	11	NC
6	CASE	12	+5V

■Order information

CR200AH-1550-100M-00

CR①-②-③-④			
①High Responsiveness Target Surface	②Spectrum Response	③Responsive Bandwidth	④Customization Requirements
200AH: 0.2mm	1550: 1550nm	30M: 30MHz	00: NO
800AH: 0.8mm	1064: 1064nm	50M: 50MHz	LN: Low noise
1000AH: 1.0mm	940 :800~940nm	70M : 70MHz	...
3000AH: 3.0mm	...	100M: 100MHz	
...		...	

Note: The laser module are ESD-sensitive devices. Please insurw that proper ESD handling procedures are followed.